

● Recommendations for Bending, Drilling, Punching & Cutting

Cuponal busbars may be readily bent, normal to the plane or on edge, by the methods outlined below. Cuponal has less spring back than copper, and as a result a bend is easier to achieve. However, a larger radius is required than with copper to allow for the flow characteristics of the copper aluminium mating face. Cuponal busbar should not be bent around a knife edge. The recommended radii for bending standard rectangular sizes of Cuponal busbar are detailed in the table. Forming pressure should be applied gradually and not by impact. Drilling and punching should be performed after bending is complete.

Recommended radius of forming tool				
Thickness t	Width w	≤90°	90° - 120°	>120
t ≤ 3	10 - 25	1t	1t	1t
3 < t ≤ 5	16 - 60	1t	2t	4t
5 < t ≤ 6.3	12 - 50	1t	2t	4t
	50 - 120	2t	3t	4t
6.3 < t ≤ 10	10 - 120	2t	3t	4t
10 < t ≤ 15	40 - 120	2t	3t	4t

N.B. Above factors are for bending normal to the plane. For edge bending the forming tool radius should be multiples of the width w.

Bending method 1

This involves pressing a forming tool against the bar, the reverse side of which is resting against two smooth supports.

The surfaces of both the forming tool and the supports must be smooth. It is important that the two supports are set sufficiently far apart to permit the bar to move and bend freely as pressure is applied to the forming tool. For angles of bend greater than ninety degrees, it may be necessary to set the supports closer together to complete the final stage of the bend.

Bending method 2

This involves holding the busbar firmly against a forming tool and applying pressure to the reverse side of the bar by means of a rolling or sliding follower. When using this method with the busbar gripped in a vice or clamp, it is important that the point of grip is sufficiently far from the bend to allow for elongation and material flow at the bend. A distance of about four times the thickness (or width for an edge bend) from the clamp to the start of the bend has proved adequate.

Drilling

Recommended drill characteristics	
Cutting speed	50m/min
Drill cutting angle	135° - 140°
Helix angle	45°
Lubricant & coolant	white spirit

Cutting

Cuponal can be cut using methods that apply to aluminium. Grinding of alternative saw teeth to a trapezoidal shape gives good results and deburring is not necessary.

Recommendations	
Cutting speed	50 - 90m/sec
Lubricant & coolant	white spirit

Punching

The punching tool should be designed in the same way as for use with flat copper bars. It is important that the die should give adequate support as near as possible to the shearing edge.

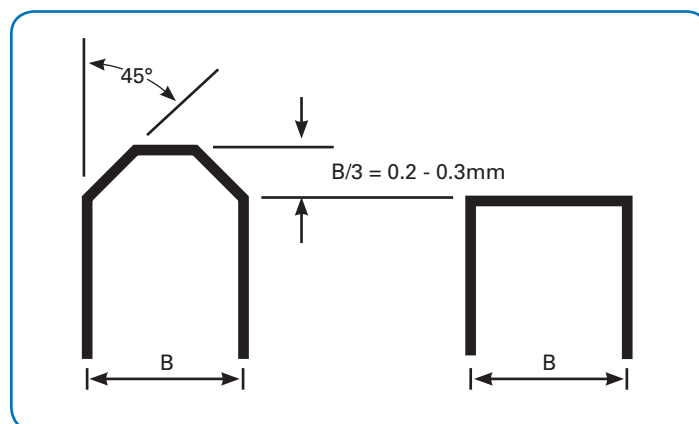

Trapezoidal teeth details